

# MODULAR COMPONENTS

## RETICLE SLEEVE WITH ILLUMINATION

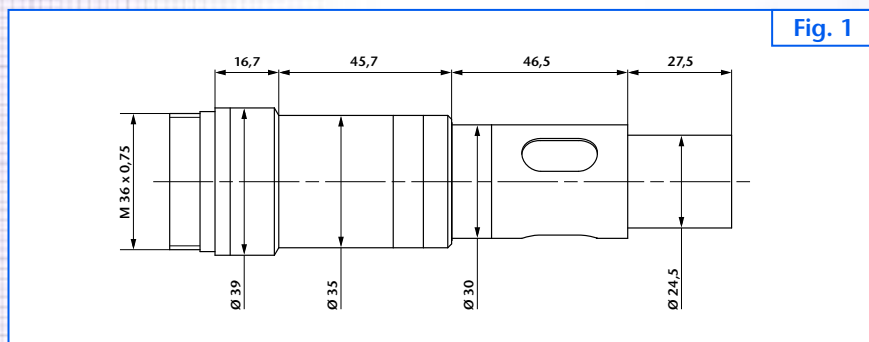

Fig. 1

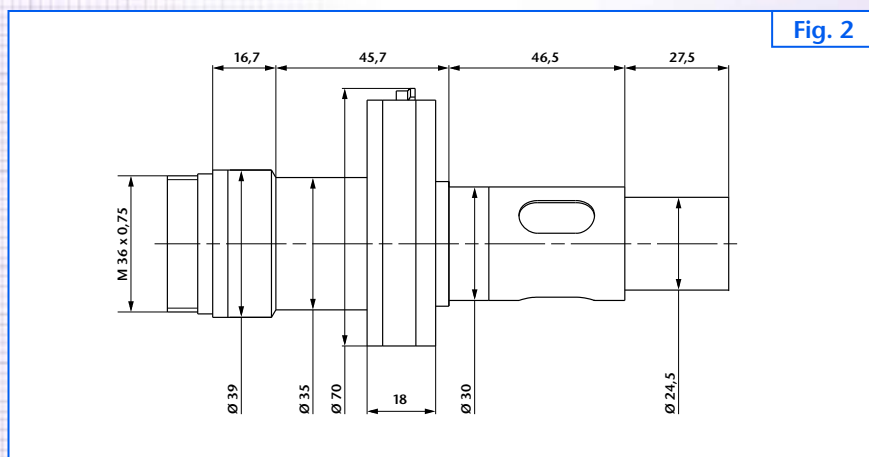

Fig. 2

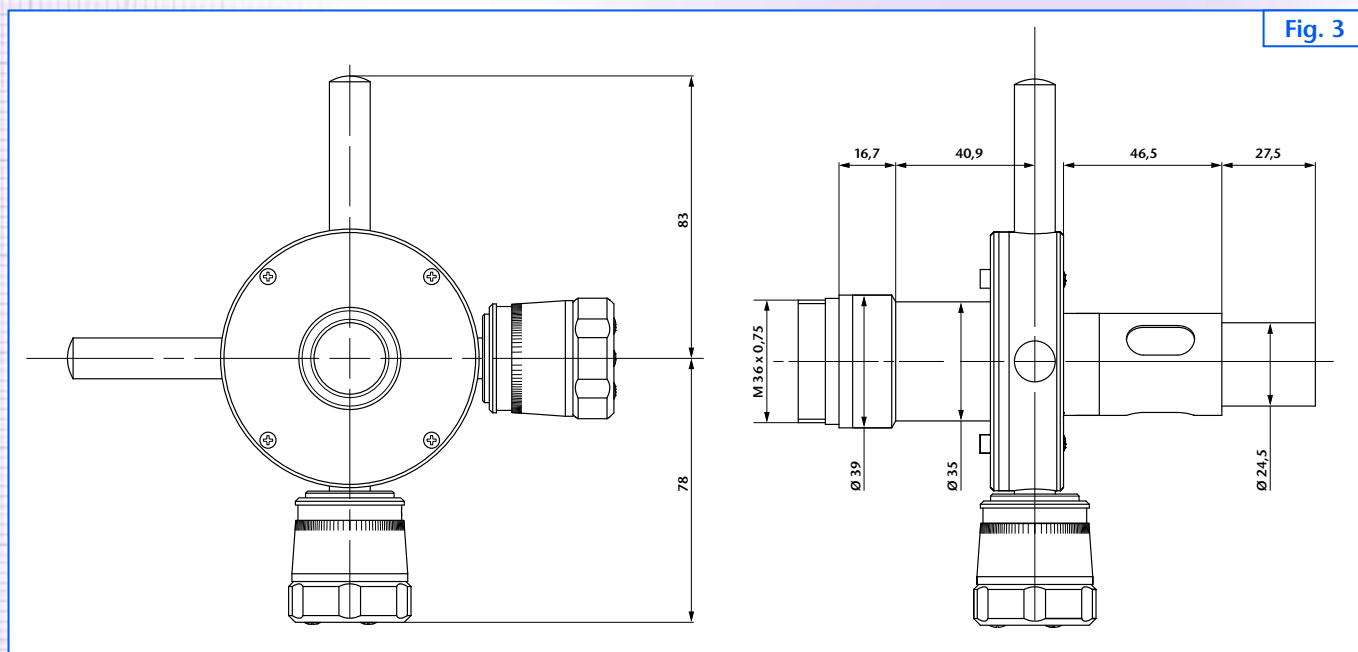

Fig. 3

Ord.-No.	Description	Fig.
215 002	Sleeve with reticle	1
217 305	Illumination	
215 023	Sleeve with reticle turret	2
217 305	Illumination	
215 042	Sleeve with double micrometer	3
217 305	Illumination	

### Notes on ordering:

Please specify reticle(s) (see page 82) and illumination (see page 81) when ordering.